

DESIGN & MAKE YOUR OWN HIFI SPEAKER CROSSOVERS

Want to try using your own combination of drivers in a hifi speaker system? It's really not hard to design your own low-pass, high-pass or bandpass filters, with either 6dB or 12dB per octave cutoff slope, to suit the drivers you want to use.

Remember that for a woofer (or subwoofer) you need a **low-pass** filter; for a tweeter, a **high-pass** filter; and for a mid-range driver, if you're using one, a **bandpass** filter. And to achieve a smooth overall response, without 'lumps' or 'dips' where the drivers take over from one another, you generally need to make the corner frequencies of their filters the same. So for a two-way system, for example, it's simply a matter of giving the woofer's low-pass filter and the tweeter's high-pass filter the same corner frequency — which becomes the **crossover** frequency, of course.

Whether you choose a 6dB/octave or 12dB/octave filter depends largely on the drivers you use, and whether they have any annoying behaviour outside their optimal frequency range, which might need the extra attenuation provided by a 12dB/octave filter. Otherwise, it's probably safer to stick with 6dB/octave filters and their smoother phase-shift performance.

Once you've decided on the corner frequency or frequencies, and the filter slope, you can if you wish work out the values for the various filter components you'll need for the filters from these formulas:

$$L = \frac{R}{2 \pi f} \quad C = \frac{1}{2 \pi f R}$$

where **L** is the filter inductance, in Henries; **C** is the filter capacitance, in Farads; **R** is the nominal impedance of the speaker driver, in ohms; **f** is the filter corner/crossover frequency in Hertz; and π is of course 'pi' (= 3.14159).

Rather than having to do a lot of calculations, though, in

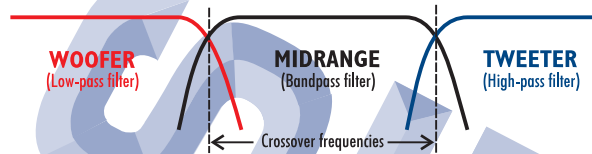

most cases you should simply be able to look up the values you'll need from the charts we've prepared below. These should save you quite a bit of time and effort.

Practical considerations

The best kind of capacitors to use in speaker crossover filters are metallised polypropylene types (for the smaller values) or non-polarised electrolytics for the larger values. Similarly for the inductors use air-cored coils for the smaller values and ferrite-bar assisted coils for the larger values (NOT iron-cored coils — they introduce distortion).

What if you need a filter capacitor value that's somewhere 'in between' commonly available values? The simplest solution here is to connect two capacitors in **PARALLEL**, so their values add together to achieve the value you need. For example if you need a 13µF capacitor, you could connect a 10µF capacitor in parallel with one of 3.3µF.

The same kind of thinking applies with inductors, except that here you connect two smaller inductors in **SERIES** to achieve the desired value, not in parallel. For example if you need a 14mH coil, you could use a 9.0mH and a 5.6mH coil in series.

Note that in each of the above examples the resultant values are not **exactly** those needed, but they're 'close enough'. Generally you don't have to be highly accurate with crossover component values — in most cases a value within 5% or so of the calculated value (or the value shown in the charts) is fine. That's because speaker driver impedance varies quite a bit from the nominal value anyway, and also varies with frequency.

6 dB/OCTAVE X-OVER CHART						
X-OVER	2 OHM		4 OHM		8 OHM	
FREQ	L(coil)	C(cap)	L(coil)	C(cap)	L(coil)	C(cap)
80	4.1mH	1000uF	8.2mH	500uF	16mH	250uF
100	3.1mH	800uF	6.2mH	400uF	12mH	200uF
125	2.5mH	640uF	5.0mH	320uF	10mH	160uF
150	2.0mH	530uF	4.0mH	260uF	9.0mH	130uF
200	1.6mH	400uF	3.5mH	200uF	6.8mH	100uF
260	1.2mH	300uF	2.5mH	150uF	5.0mH	75uF
400	.8mH	200uF	1.6mH	100uF	3.3mH	50uF
600	.5mH	140uF	1.0mH	70uF	2.0mH	35uF
800	.4mH	100uF	.8mH	50uF	1.6mH	25uF
1000	.3mH	80uF	.6mH	40uF	1.2mH	20uF
1500	.2mH	50uF	.4mH	25uF	.8mH	13uF
2000	.15mH	40uF	.3mH	20uF	.6mH	10uF
3000	.1mH	25uF	.2mH	13uF	.4mH	6.6uF
4000	.08mH	20uF	.15mH	10uF	.3mH	5uF
5000	.06mH	16uF	.12mH	8uF	.25mH	4uF
6000	.05mH	13uF	.1mH	6.6uF	.2mH	3.3uF
8000	.04mH	10uF	.08mH	5uF	.16mH	2.5uF
10000	.03mH	8uF	.06mH	4uF	.12mH	2uF

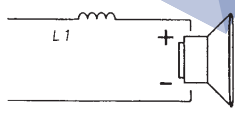

6 dB/OCTAVE LOW PASS

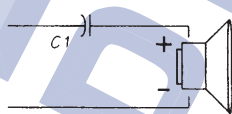

6 dB/OCTAVE HIGH PASS

12 dB/OCTAVE X-OVER CHART						
X-OVER	2 OHM		4 OHM		8 OHM	
FREQ	L(coil)	C(cap)	L(coil)	C(cap)	L(coil)	C(cap)
80	5.6mH	700uF	11mH	330uF	22mH	180uF
100	4.5mH	550uF	9mH	270uF	18mH	135uF
125	3.5mH	450uF	7mH	220uF	14mH	110uF
150	3.0mH	375uF	6.0mH	180uF	12mH	90uF
200	2.3mH	281uF	4.5mH	140uF	9mH	70uF
260	1.7mH	220uF	3.5mH	100uF	7mH	50uF
400	1.1mH	140uF	2.2mH	70uF	4.5mH	35uF
600	.75mH	100uF	1.5mH	50uF	3.0mH	25uF
800	.56mH	68uF	1.0mH	33uF	2.0mH	15uF
1000	.45mH	55uF	.9mH	27uF	1.8mH	13uF
1500	.3mH	36uF	.6mH	18uF	1.2mH	10uF
2000	.22mH	28uF	.45mH	14uF	.9mH	7uF
3000	.15mH	19uF	.3mH	10uF	.6mH	4.6uF
4000	.11mH	14uF	.225mH	7uF	.45mH	3.5uF
5000	.09mH	10uF	.18mH	5.6uF	.36mH	2.8uF
6000	.075mH	9.3uF	.15mH	4.6uF	.3mH	2.3uF
8000	.056mH	7uF	.11mH	3.5uF	.25mH	1.7uF
10000	.045mH	5.6uF	.09mH	2.8uF	.18mH	1.4uF

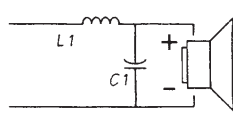

12 dB/OCTAVE LOW PASS

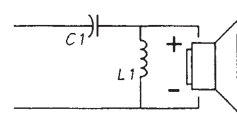

12 dB/OCTAVE HIGH PASS

Speaker connections & impedance matching

When you're designing your own speaker systems, one of the things that can make life complicated is impedance matching considerations. For example you may have some very good 8Ω speakers you'd like to use, but your amplifier is designed to deliver its maximum output into 16Ω loads. Or alternatively you may have some excellent 8Ω speakers, which you want to use with an amplifier designed for 4Ω loads. Or perhaps you just want to use multiple speakers on each channel of your system, to boost its power handling capability.

In most cases the solution is to connect your speakers in either series, parallel or series/parallel, as shown in the diagrams below. As you can see with speakers in **series** their impedances simply add together, like resistors — so two 8Ω drivers in series will produce 16Ω . Or connected in **parallel**, they'll produce 4Ω . Or if you connect four 8Ω speakers in **series/parallel**, they'll produce a resultant impedance that still presents 8Ω to the amplifier, but your speakers can now handle approximately four times the power.

Note that when you connect multiple speakers together in these ways, you need to be careful with their polarities — as shown in the diagrams. This is to ensure that they don't 'fight' each other in terms of their sound output, but 'push' and 'pull' together...

Finally, the last diagram shows how speakers are hooked up

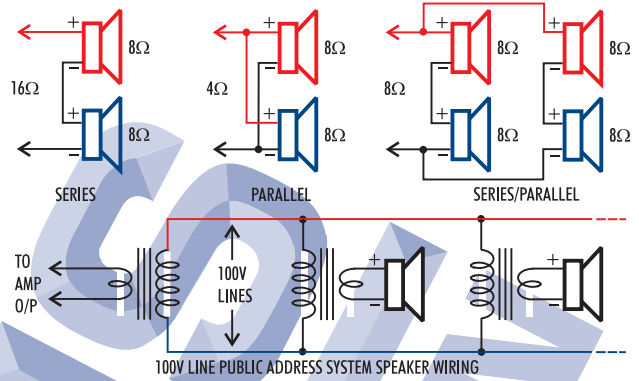

in public address systems using the '100V line' system. Here they're all connected in parallel across the 100V line, but via their individual matching transformers. The amplifier has a transformer too.

(Copyright © Electus Distribution, 2001)

ELECTUS DISTRIBUTION